

<p><b>NOTES:</b></p> <p>Specifications:</p> <ul style="list-style-type: none"> <li>- barrel grinding, R=687mm</li> <li>- Polished finish</li> <li>- Sensitivity 10' ± 30" per 2mm bubble movement</li> </ul> <p>Filling:</p> <ul style="list-style-type: none"> <li>- Liquid n-Heptane(min 99/9% purity)</li> <li>- Airbell 12.0±0.3mm at 20°C</li> </ul> <p>Finish:</p> <ul style="list-style-type: none"> <li>- Outside Glass surface to be free from scratches</li> <li>- No finger prints</li> <li>- No internal or external dust particles</li> </ul> <p>Packing:</p> <ul style="list-style-type: none"> <li>- Antistatic tape and reel, 200 pcs per reel</li> </ul> <p>Inspection:</p> <ul style="list-style-type: none"> <li>- 100% automated vision inspection for vial Length, bubble size and hysteresis.</li> </ul> <p>Performance:</p> <ul style="list-style-type: none"> <li>- Resolution &lt; 1 arc second</li> <li>- Hysteresis &lt; 10 arc seconds</li> <li>- Operating temperature range -20°C to 70°C</li> <li>- Storage temperature range -40°C to 80°C</li> </ul>		<p><b>SYMBOL</b></p>	<p><b>REVISION RECORD</b></p>	<p><b>DATE</b></p>
---	--	----------------------	-------------------------------	--------------------

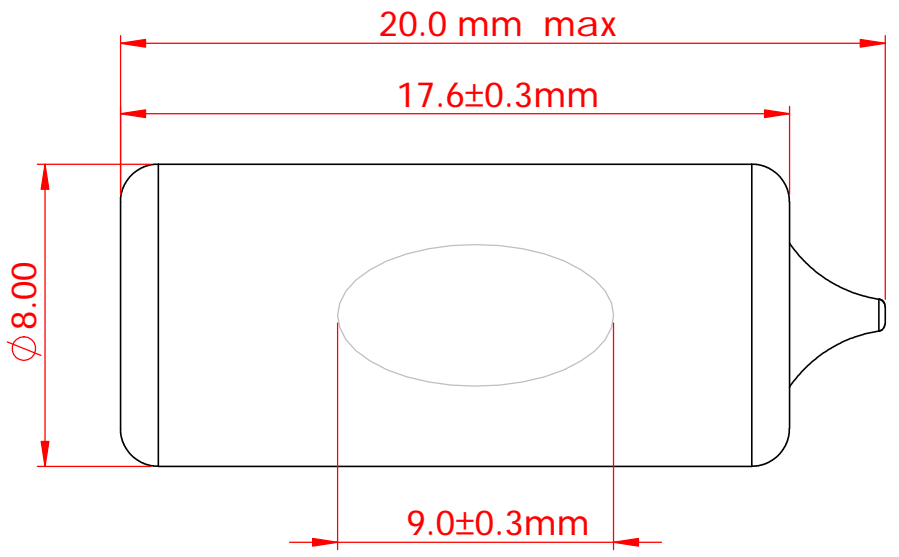

<p><b>L.V Level Co.,Ltd</b>  <a href="http://www.level-tool.com">www.level-tool.com</a>  <a href="mailto:sail@level-tool.com">sail@level-tool.com</a></p>	<p>Unless Otherwise Specified:Units: mm  Tolerances: XX. ± 1.0   XX.X ± 0.25   XX.XX ± 0.1</p>	<p><b>MATERIAL:</b> soda glass tube, 8mm Dia</p> <p><b>SCALE:</b> 1:1</p>	<p><b>DRAWN BY:</b> liu</p>	<p><b>DATE:</b> 2008-12-23</p> <p><b>DRAWING NUMBER</b> 6610/7</p>
---	--	---	---------------------------------	--